



**RadioLINK**  
**MAINS POWERED**  
**CARBON MONOXIDE ALARM**  
**WITH RECHARGEABLE LITHIUM CELL BACK-UP**



The RadioLINK Carbon Monoxide Alarm Ei262 will communicate with all other RadioLINK devices including Smoke/Heat/Fire Alarms, Relays and other accessories.

**Model Ei262**











Read and retain carefully for as long as the product is being used. Contains vital information on the operation and installation. This leaflet should be regarded as part of the product.

If you are just installing the unit, **this leaflet must be given to the householder**. This leaflet is to be given to any subsequent user.

# CONTENTS

	Page
<b>1 IMPORTANT INFORMATION</b>	<b>3</b>
What to do when you alarm is activated	4
<b>2 CARBON MONOXIDE - THE SILENT KILLER</b>	<b>5</b>
<b>3 ALARM POSITIONING</b>	<b>9</b>
<b>4 INSTALLATION</b>	<b>13</b>
4.1 Mounting & Wiring Alarms	13
4.2 RadioLINK Interconnecting etc.	17
<b>5 USING &amp; TESTING YOUR SYSTEM</b>	<b>20</b>
<b>6 HOW TO DISTINGUISH BETWEEN CO ALARM &amp; SMOKE ALARM WARNINGS</b>	<b>22</b>
<b>7 MAINTENANCE</b>	<b>22</b>
<b>8 LIMITATIONS OF CO ALARMS</b>	<b>23</b>
<b>9 HOW TO PROTECT YOUR FAMILY</b>	<b>27</b>
<b>10 GETTING YOUR CO ALARM SERVICED</b>	<b>28</b>
<b>11 FIVE YEAR GUARANTEE</b>	<b>28</b>
<b>12 TECHNICAL SPECIFICATIONS</b>	<b>29</b>
<b>13 ACCESSORIES</b>	<b>33</b>
<b>14 TROUBLESHOOTING</b>	<b>34</b>

## 1. IMPORTANT INFORMATION

-  **WARNING:** The Alarm should be permanently wired to the mains by a qualified electrician in accordance with IEE wiring regulations (BS7671).
-  Install a Carbon Monoxide (CO) Alarm in every room that contains a fuel burning appliance, and in rooms where people spend a lot of time e.g. bedrooms, kitchens and sitting rooms.
-  In rooms with an fuel burning appliance, install (preferably) on the ceiling (300mm from walls and between 1m to 3m horizontally from appliance). In rooms remote from the appliance install at breathing level, where the light indicators can be seen.
-  Regularly check that the green power light is on, so that rechargeable back-up cells will remain fully charged. **Important:** The CO Alarm will not work if the mains supply is off and the rechargeable cells are depleted.
-  Test the unit weekly by pressing and holding the Test/Hush button. The horn will sound and the radio frequency (RF) signal will be transmitted. (Green light turns red while RF message is transmitted).
-  Replace sensor module after 5 years operation (see page 25).
-  When the CO Alarm detects abnormal levels of CO (above 50ppm CO) the **red light** starts to flash, the horn will sound within 90 minutes and the **RadioLINK** signal will be transmitted. At higher levels of CO the alarm will turn on sooner (see Table B - page 7).
-  The CO Alarm will automatically reset once the CO has cleared. Pressing the Test/Hush button will silence the CO Alarm immediately (below 300ppm CO). If CO is still present the red light and horn will turn on again after about 4 minutes.
-  The CO Alarm is no substitute for keeping chimneys and flues clear and in good condition, and all of your appliances serviced regularly according to the manufacturer's instructions.
-  Do not fit alarm until all building work is completed to avoid contamination.

## WHAT TO DO WHEN THE CARBON MONOXIDE ALARM IS ACTIVATED:



- (1) Open the doors and windows to ventilate the area.
- (2) Turn off all fuel appliances where possible. (The alarm can be silenced immediately, with low levels of CO, by pushing the Test/Hush button).
- (3) Evacuate the property leaving the doors and windows open.
- (4) Get medical help immediately for anyone suffering the effects of Carbon Monoxide poisoning (headache, nausea), and advise that Carbon Monoxide poisoning is suspected.
- (5) Ring your gas or other fuel supplier on their emergency number. Keep the number in a prominent place.
- (6) Do not re-enter the property until the alarm has stopped. (If the alarm has been silenced by pressing the Test/Hush button, wait at least 5 minutes. The alarm will then check that the CO has cleared).
- (7) Do not use the fuel appliances again until they have been checked by an expert. In the case of gas appliances this must be a Registered Gas Installer.

**Note:** If the Ei262 Carbon Monoxide Alarm is interconnected to Smoke/Heat Alarms, quickly press the Locate Button (on Remote Switches Ei411H3 or Ei1529) to silence all alarms except the one sensing danger and/or find the alarm with the red light flashing rapidly. If it is a carbon monoxide leak follow the above instructions. If it is a fire, evacuate the premises closing all doors as you go, ring the fire brigade and follow the other smoke/heat alarm emergency instructions.

## 2. CARBON MONOXIDE - THE SILENT KILLERS

### 2.1 WHAT IS CARBON MONOXIDE ?

Congratulations on becoming the owner of an Ei Carbon Monoxide Alarm. This will help protect you and your household from the dangerous effects of Carbon Monoxide - The Silent Killer. Many are killed each year, and many more suffer ill health from Carbon Monoxide (CO) poisoning (CO is the chemical symbol, indicating the molecule has one carbon atom and one oxygen atom). CO is an invisible, odourless, tasteless and extremely toxic gas. It is produced by appliances and vehicles burning fuels, such as coal, oil, natural/bottled gas, paraffin, wood, petrol, diesel, charcoal etc. CO is absorbed by red blood cells in the lungs in preference to oxygen - this results in rapid damage to the heart and brain from oxygen starvation.

#### **High levels of CO in a house can be caused by:**

- Incorrectly or poorly installed fuel-burning appliances.
- Blocked or cracked chimneys/flues.
- Blocked vents or draught-proofing which makes areas with fuel burning appliances or fireplaces airtight.
- Engines of cars, lawnmowers etc. left running in confined spaces.
- Portable paraffin or gas heaters in badly ventilated rooms.
- Charcoal barbecues burning indoors.

### 2.2 SYMPTOMS OF CARBON MONOXIDE POISONING

Most people know that high levels of CO are harmful, however the period of exposure is also important.

A low level for a long period (e.g. 150 ppm for 90 minutes) can cause the same symptoms (a slight headache) as a high level of CO for a short period (e.g. 350 ppm CO for 30 minutes). Table A shows how exposure to different concentrations of CO generally affects people.

Many cases of reported Carbon Monoxide poisoning indicate that while victims are aware they are not well, they become so disorientated they are unable to save themselves by either leaving the building or calling for assistance. Young children and household pets may be the first affected.

**Table A: Effects of Carbon Monoxide Poisoning**

Concentration of CO in Air ppm	Inhalation Time (approx) and Symptoms Developed
35	The maximum allowable concentration for continuous exposure in any 8 hour period according to OSHA *.
150	Slight headache after 1.5 hours.
200	Slight headache, fatigue, dizziness, nausea after 2-3 hours.
400	Frontal headaches within 1-2 hours, life threatening after 3 hours, also maximum parts per million in flue gas (on an air free basis) according to US Environmental Protection Agency.
800	Dizziness, nausea and convulsions within 45 minutes. Unconsciousness within 2 hours. Death within 2-3 hours.
1,600	Headache, dizziness and nausea within 20 minutes. Death within 1 hour.
3,200	Headache, dizziness and nausea within 5-10 minutes. Death within 25-30 minutes.
6,400	Headache, dizziness and nausea within 1-2 minutes. Death within 10-15 minutes.
12,800	Death within 1-3 minutes.

▲ ppm = parts per million

\*OSHA = Occupational Safety & Health Association

## 2.3 WHAT HAPPENS WHEN YOUR CO ALARM DETECTS CARBON MONOXIDE ?

When the Ei262 CO Alarm detects potentially dangerous levels of CO, it flashes the red alarm light and then sounds a loud alarm if the CO persists and transmits a **RadioLINK** alarm signal.

Table B below shows how the CO Alarm reacts to different levels of CO gas and exposure time. At higher levels of CO the alarm turns on sooner. The rate of flashing of the red light indicates the level of CO.

**Table B: CO Alarm Response**

CO Level (ppm)	Red Alarm Light	Horn sounds within
0	Off *	Off
50	1 Flash / 2 Seconds	60 to 90 minutes
100	2 Flashes / Second	10 to 40 minutes
300	4 Flashes / Second	3 minutes

\* unless it has been in alarm (see 2.4 CO Alarm Memory overleaf)

**If your CO Alarm sounds follow the instructions on page 4.**

When ventilation is provided by leaving windows and doors open, the CO build up may have dissipated by the time help arrives and the alarm may have stopped sounding. Although your problem may appear temporarily solved, it is crucial that the source of the CO is determined and appropriate repairs made.

## **NEVER IGNORE THE ALARM.**

**Pre-Alarm:** When the alarm detects over 50ppm CO the red light flashes every 2 seconds. This helps locate CO leaks as the unit gives a visible indication straight away (the horn will not sound unless the 50ppm of CO remains for at least 90 mins). Note the Pre-Alarm signal may be triggered by CO coming for example, from cooking with gas, from car engines or from nearby barbecues. This is usually not a concern unless the Pre-Alarm signal persists until the alarm sounds and the CO source is unknown.

**Note:** The CO Alarm may pre-alarm if cigarette smoke is blown into it, or aerosols are released nearby.

### **2.4 CO ALARM MEMORY**

When the Test button is pressed the horn will sound, and the alarm red light will only flash if the unit has previously detected CO and been in alarm. The flash rate indicates the level of CO detected as below:-

- **Alarm Red light is Off** – No CO detected since reset or power up.
- **Alarm Red light flashes 2 times** (in 2 seconds) every 40 seconds - 50 ppm CO detected for approximately 90 minutes since reset or power-up.
- **Alarm Red light flashes 4 times** (in 2 seconds) every 40 seconds - 100 ppm CO detected for approximately 40 minutes since reset or power-up.
- **Alarm Red light flashes 8 times** (in 2 seconds) every 40 seconds - 300 ppm CO detected for approximately 3 minutes.

**Reset Memory** by holding down the Test button for over 20 seconds until the alarm red light stops flashing. Cover the horn with a cloth to muffle the alarm during this time. (Note any other **RadioLINK** device will also alarm during this period).

Please note that the memory will also be reset when the unit is removed from the mounting plate.



## 3. ALARM POSITIONING

### 3.1 IDEALLY A CARBON MONOXIDE (CO) ALARM SHOULD BE INSTALLED IN:

- Every room containing a fuel burning appliance
- Remote rooms where occupants spend a considerable amount of time
- Every bedroom

However if the number of CO Alarms is limited, the following points should be considered when deciding where best to fit the alarm(s)

- If there is an appliance in a room where people sleep, place a CO Alarm in this room
- Locate a CO Alarm in a room containing a flueless or open-flued appliance
- Locate a CO Alarm in a room where the occupant(s) spend most of their time (e.g. living room)
- In a bedsit, the CO Alarm should be placed as far away from the cooking appliance as possible, but near to where the occupant sleeps
- If the appliance is in a room not normally used (such as a boiler room) the CO Alarm should be placed just outside the room so that the alarm will be heard more easily

### 3.2 UNSUITABLE LOCATIONS

**Do not** place the CO Alarm in any of the following areas

- In a position, where access to the screwdriver slot to release the CO alarm from its mounting plate, is blocked by an object such as a wall, a fixed item of furniture or skirting board, as this would make removal or replacement of the CO alarm impossible without damaging it. See *Figure 4* for screwdriver slot location on the CO alarm.

- In the immediate vicinity of a cooking appliance
- Outside the building
- In an enclosed space (e.g. in or below a cupboard)
- In a damp or humid area
- Directly above a sink or cooker
- Next to a door, window, air vent or anywhere that it would be affected by draughts
- Next to an extractor fan
- Do not locate over heat sources such as radiators or hot air vents
- Where it would be obstructed, e.g. by curtains or furniture
- In an area where the temperature could drop below  $-10^{\circ}\text{C}$  or rise above  $40^{\circ}\text{C}$
- Where dirt or dust could block the sensor
- Where it could be easily knocked or damaged, or where it could be accidentally turned off or removed
- In a bathroom or other areas where the CO Alarm may be exposed to water splashes, dripping or condensation (e.g. above an electric kettle)
- Near paint, thinners, solvent fumes or air fresheners

### **3.3 IF LOCATING THE CO ALARM IN A ROOM WITH A FUEL BURNING APPLIANCE (see Figure 1)**

- If it is mounted on a wall, it should be located at a height greater than the height of any door or window but still be at least 150mm from the ceiling
- If it is mounted on the ceiling it should be at least 300mm from any wall or light fitting
- The CO alarm should be a horizontal distance of between 1m and 3m from the potential CO source
- If there is a partition in the room, the CO Alarm should be located on the same side of the partition as the potential source
- In rooms with sloped ceilings, the CO Alarm should be located at the high side of the room (see *Figure 3*)

### 3.4 IF LOCATING THE CO ALARM IN A BEDROOM OR IN ROOMS REMOTE FROM A FUEL BURNING APPLIANCE (see Figure 3)

- Mount the CO alarm relatively close to the breathing zone of the occupants

Whatever position is chosen make sure it is possible to view the three light indicators, when in the vicinity of the alarm.

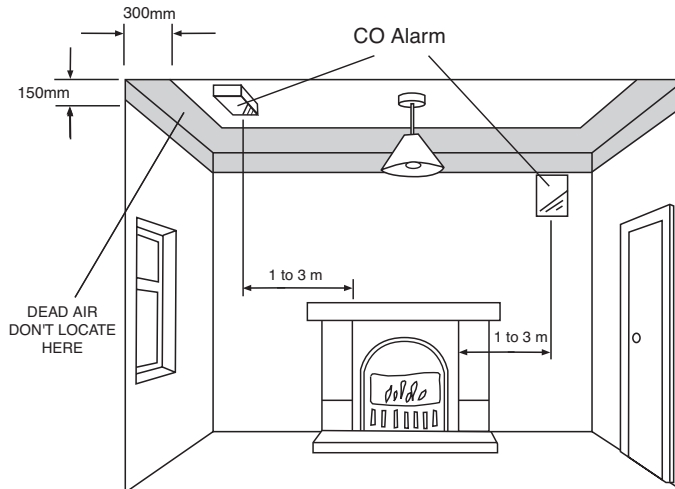

**Figure 1.** Location in room with a fuel burning appliance

- 1 to 3m from appliance

- Ceiling 300mm (min) from walls - Wall 150mm vertically down from ceiling

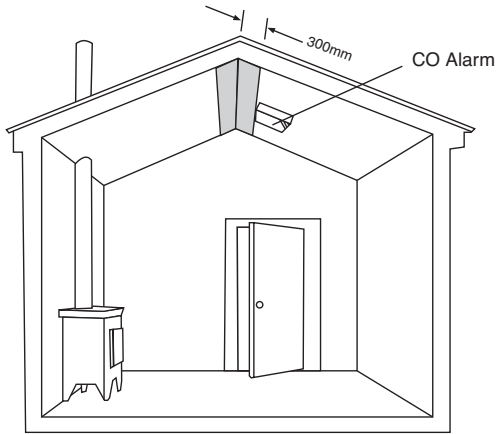

**Figure 2.** Location in rooms with sloped ceilings

- 300mm from apex of ceiling
- High side of the room

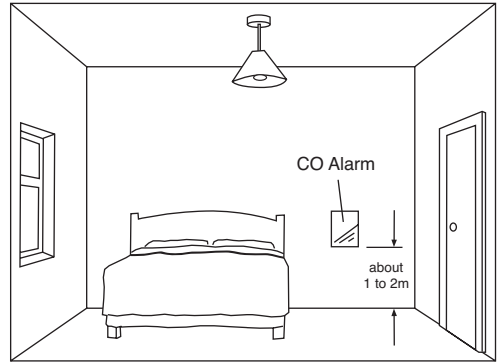

**Figure 3.** Location in bedroom & rooms remote from the appliance

- Wall mounted
- Breathing level (approx. 1 to 2m above floor)

## 4. INSTALLATION

### 4.1 Mounting & Wiring your alarm

The Alarm is designed to be permanently mounted, using its own built-in terminal block to connect it to the mains wiring. The mounting plate can be screwed directly to the ceiling/wall. Alternatively it can be screwed to a standard junction box (BS 4662 single gang accessory box). The alarm requires a current of 90mA. The Alarm must not be exposed to dripping or splashing. There are important markings on the underside of the alarm.

**IMPORTANT PRECAUTION:** Do not install the actual alarm itself in new or renovated buildings until all work is completed (including floor coverings) and the building has been fully cleaned. The wiring can be installed when appropriate. (Excessive dust and debris from building work can contaminate the sensor and cause problems, it will also invalidate the guarantee). If it must be installed, cover it completely, particularly around the edges, with a suitable covering, until all cleaning is finished.

Figure 4 - Alarm Installation & Removal

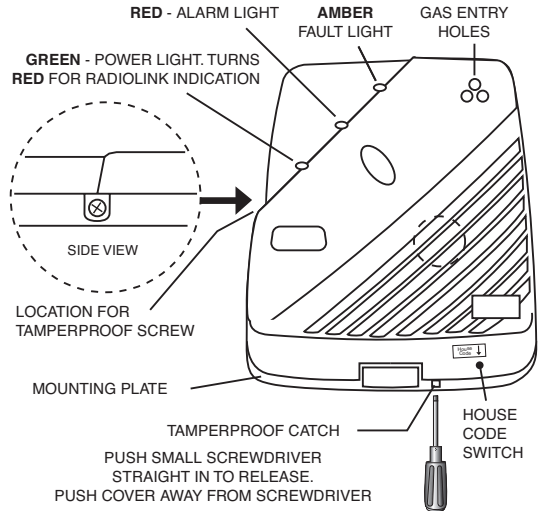

**WARNING:** DISCONNECT MAINS BEFORE REMOVING ALARM FROM CEILING OR WALL

The Alarm must **not** be connected when the house wiring insulation is being checked with high Voltages i.e. do not use an insulation tester on the alarm.

- ! Do not use the Alarm on an intermittent basis, or as a portable detector for the leakage of combustion products from fuel burning appliances or chimneys.
- ! The Alarm should be installed and interconnected by a qualified electrician in accordance with the Requirements for Electrical Installations published by the Institution of Electrical Engineers (as BS7671). Failure to install this Alarm correctly may expose the user to shock or fire hazards.
- ! The Alarm must be continuously powered 24 hours a day so it is important that it is not on a circuit that can be turned off by a switch.

**Light Dimmer Circuits** – The Alarms **must not** be powered through a light dimmer circuit. This will also cause overheating and damage the Alarm.

## **INSTALLATION PROCEDURE**

1. Select a location complying with the advice in the previous section.
2. Disconnect the AC mains supply from the circuit that is going to be used to power the Alarm.
3. The house wiring must be connected to the terminal block on the mounting plate as follows:
  - L: Live** - connect to the house wires coloured brown or marked L.
  - N: Neutral** - connect to the house wires coloured blue or marked N.
  - IC: Interconnect** - Not normally used.

**Warning:** Mixing the Live and Neutral connections when interconnecting alarms will damage all the alarms - ensure that the same colours are used throughout the premises for Live, Neutral & Interconnect wires.

We strongly recommend that you check for the following **before connecting the alarm**:

- check for Live and Neutral using a two probe tester.
- check for Live using a neon tester.
- check that the Interconnect is NOT connected to Live, Neutral or Earth. **Do not connect an Earth wire to the Interconnect.**

**Note:** The Alarm does not need to be earthed. However the terminal marked  is provided for the convenience of the installer so that any copper Earth wire or cable coloured green & yellow, can be safely terminated.

4. Lift off the wiring cover as shown in *Figure 5* overleaf.

5. If the mains wires are being brought along the surface, conduit can be inserted into the top and/or bottom of the mounting plate.

(a) position the mounting plate, so that the cable conduit is as shown in *Figure 5* overleaf.

(b) Carefully cut around the knockout on the outside wall so the conduit fits. (**Note:** to comply with the EN 60529, IPX2D protection rating, seal around conduit with silicone rubber or similar to prevent water entering).

6. If the mains wiring is recessed, bring the wiring through the rear hole in the mounting plate as shown in *Figure 6*.

7. Carefully align the mounting plate and screw into place. Connect the wires to the terminal block. With recessed wiring, ensure the rear gasket seals around the edge of the hole in the ceiling or wall. This is to prevent air draughts affecting the CO gas entering the Alarm. If the hole is not closed off by the gasket it should be sealed with silicone rubber or equivalent.

**Note:** House wiring should not be “bunched up” in the area of the Alarm but quickly and neatly directed away. This will minimize their effect on the radio antenna.

8. Replace the wiring cover.

9. Carefully line up the unit on the base and slide on.

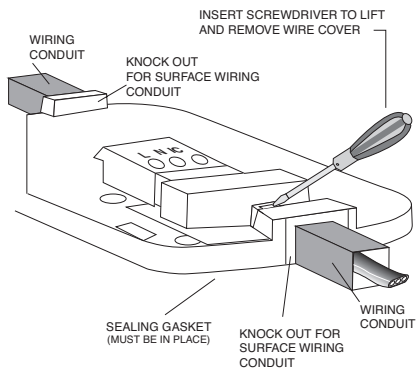

**Figure 5 - Surface Wiring**

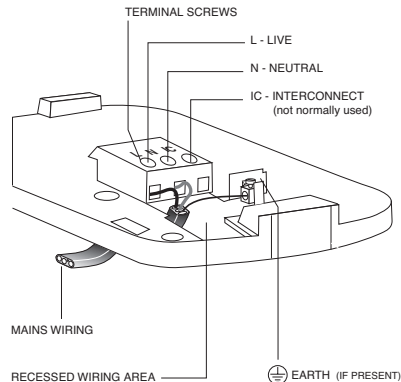

**Figure 6 - Recessed Wiring**

**10. It is essential to House Code the Alarm to ensure it will not accidentally communicate with nearby systems (even if you do not plan to use the *RadioLINK* feature yourself). This is easily done as explained in Section 4.2.**

(As a safety feature the Alarms will all communicate with each other (provided they are within range) as installed i.e. without any House Coding. The repeater function is disabled when units are not House Coded).

**11. Connect the mains power to the alarm circuit. Check the green light is on.**

The CO Alarm is now fully operational and will provide protection against a build up of Carbon Monoxide gas after it has been connected to the mains supply for over 70 seconds.



12. Press the Test/Hush button for 5 seconds. The horn will sound. The ‘power’ green light will then turn red and the **RadioLINK** signal will be transmitted. Check that any interconnected alarms also sound within this period.
13. The unit may be tamperproofed further by removing the knockout in the sidewall of the mounting plate (as shown in *Figure 4*) and inserting the self tapping screw (3mm diameter, 12mm long) after the unit is on the mounting plate.

## 4.2 RadioLINK Interconnection

The Ei262 will transmit a **RadioLINK** alarm signal when it detects potentially dangerous levels of CO. This **RadioLINK** Alarm signal can be used to:

1. Wirelessly interconnect to other Ei Electronics **RadioLINK** Smoke/Heat Alarm devices (e.g. Smoke/Heat Alarms mounted on Ei168RC **RadioLINK** Professional bases), so that all units will go into alarm when the Ei262 senses alarm levels of CO gas and also the Ei262 will go into alarm when the other devices sense fire.

The Ei262 may be interconnected with up to 12 Ei161RC/Ei164RC/Ei166RC/Ei2110 Smoke/Heat/Fire Alarms (on Ei168RC **RadioLINK** Professional Bases) **provided an Ei411H Remote Control is used** in the system (see “ACCESSORIES” section).

If interconnected CO and Smoke/Heat Alarms are all sounding, the LOCATE switch on the Ei411H Remote Control should be pressed. This will just leave the alarm that triggered the system sounding.

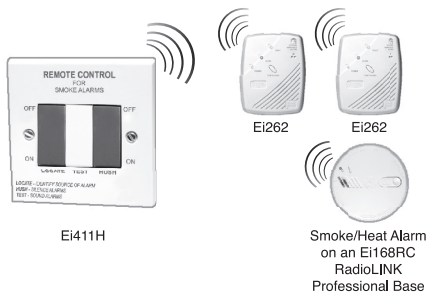

This is very important to determine which alarm is sounding because the actions to take in each situation are very different.

In the case of CO the premises should be fully ventilated by opening doors and windows. The user should call the gas supplier etc.

In the case of fire, doors and windows should be closed to slow the spread of fire. The user should call the fire brigade etc.

2. Wirelessly communicate with Ei Electronics **RadioLINK** accessories such as the Ei428 **RadioLINK** Relay (e.g. for shutting off gas valves).

#### 4.2.1 Interconnection

After all the **RadioLINK** units have been installed they must all be House Coded as follows:

##### House Coding your alarm

1. Press and hold the House Code switch on the bottom of the cover with a small screwdriver until the green power light turns red (see figure 7).
2. Immediately release the switch and the light will flash red (alternating with green) quickly a few times. The red light will then flash every 5 or 10 seconds (depending on number of units coded - see below). Repeat this action on all other Ei262 Alarms in the property as quickly as possible (within 15 minutes).
3. Now put any other **RadioLINK** units in the property into House Code mode (see their separate instruction manuals for details) within 15 minutes.
4. Check that the Ei262 is House Coded to all the other **RadioLINK** devices in the property by counting the number of times the red light flashes (alternating with the green) every 5 (or 10) seconds. For example, with just the Ei262 on its own in the “system” it will give one red light flash every 5 seconds,

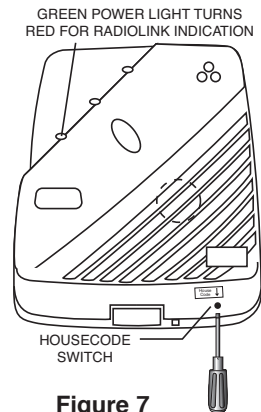

Figure 7

with 3 units in the system should give 3 short flashes every 5 seconds, 4 units should give 4 short flashes and so on, up to 12 units. It may take up to 30 minutes for all the units in the system to be House Coded correctly. Check that the other **RadioLINK** units are House Coded as per their instructions. If at the end of this period certain units do not show the correct number of flashes, repeat the process (from point 1 above) once more and if this fails see - *Section 14 Troubleshooting on page 36*.

5. The units will automatically exit the House Code learn mode after 30 minutes however **we recommend that you manually exit the House Code mode** by pressing and holding the House Code switch on the Ei262 until the **RadioLINK** Indicator light turns red, and then release. The **RadioLINK** Indicator light should stop flashing and an 'exit House Code' signal will be sent to all other units.

Check that the **RadioLINK** Indicator lights on all other units have stopped flashing. (If some units are still flashing it may indicate a problem with the radio communication from this unit to the other units, or these units may have to be taken out of House Code mode manually, see their instruction manuals. Repeat the process once more and if this fails see - *Section 14 Troubleshooting on page 36*. Manually exiting the House Code mode reduces the risk of accidentally House Coding your **RadioLINK** units with nearby systems).

6. Check the communications by pressing the Test/Hush button on the Ei262 for up to 10 seconds. The alarm will sound and then pause briefly while the **RadioLINK** signal is transmitted. The green power light will turn red for this duration (approx 3.5 seconds). All other alarms should sound (this may take up to 20 seconds as the signal may need to be relayed through "repeaters" - see next page). Release the Test/Hush button. The local alarm will cease and you should then be able to hear the other alarms sounding in the distance and then stopping. Note: The local alarm may sound again depending on the number of repeaters in the system as it acknowledges the repeated signals. Similarly check each **RadioLINK** unit in the same way (if any of the alarms do not sound, see - *Section 14 Troubleshooting*).

When button testing units in sequence it is important to wait 15 seconds plus a further 6 seconds per repeater between button tests (e.g. for a system with 10 repeaters, time to wait: 15 seconds + 10 x 6 seconds = 75 seconds between button tests).

Finally attach the label provided to the distribution board to identify the alarm circuits.

(Note: If it is necessary to clear House Codes see section 12, page 31 - Technical Specification).

## The “Repeater” Function

All Ei262 CO Alarms are set as “Repeater” units as supplied. The function of a Repeater unit is to receive and then re-transmit the RF signals. This provides multiple signal paths throughout the installation to give improved RF signal reliability (with 3 or more **RadioLINK** units).

Note the “Repeater” function is not operational until all the units are put in to House Code mode.

The operation of the “Repeaters” can be observed as each unit turns on its **RadioLINK** Indicator light as a **RadioLINK** message is being repeated.

(Note: If it is necessary to disable the Repeater function see section 12, page 32 - Technical Specification).

### 4.2.2 **RadioLINK** Accessories

When using **RadioLINK** accessories simply install all the units as per their instructions first. Then follow the House Coding and checking procedure described in 4.2.1 above.

## 5. USING AND TESTING YOUR SYSTEM

### 5.1 Using the System

If the Alarm is sounding (with its red alarm indicator flashing at least once every 2 seconds) – immediately follow the instructions on page 3 “What to do when the Carbon Monoxide Alarm is activated”.

If you have interconnected CO Alarms and Smoke/Heat Alarms and they are all in alarm, then quickly press the “Locate” button (on the Ei411H Remote Control Switch) to silence all the alarms except the one sensing danger.

If a Remote Control Switch is not fitted, find the alarm with its red alarm light flashing rapidly – if it is a Carbon Monoxide Alarm follow the instructions on page 4.

If it is a fire, evacuate everybody from the premises, closing all doors as you leave, call the Fire Brigade and follow the other emergency instructions supplied with your Smoke/Heat Alarm.

(Note: When all the alarms are sounding you must not press the hush button on the Ei411H until you know which unit caused the alarm).

## 5.2 Testing the System

**5.2.1.** Regularly check that the green mains power light is on. The unit cannot detect CO if the mains power is off and the rechargeable battery back-up is depleted. (If it is off check circuit breakers, fuses, wiring etc).

**5.2.2.** Test the unit weekly by pressing the Test/Hush button. Hold the button (for up to 10 seconds) until the horn sounds for over 5 seconds & the **RadioLINK** Indicator light turns red for about 3.5 seconds (the horn will pause during the RF transmission). Any other interconnected devices should now sound. Release the Test/Hush button. The local alarm will cease and you should then be able to hear any other alarms sounding in the distance (if any of the alarms do not sound - see *Section 14 Troubleshooting*).

**5.2.3.** Pressing the Test/Hush button will help to familiarise you and your family with the distinctive on-off sound of the CO Alarm. This test checks that the electronics and horn are working correctly. (If the red alarm light flashes when the button is pressed, see Section 2.4 “CO ALARM MEMORY”). Alternatively, if an Ei411H Remote Control Switch is in the system the Alarm can be tested by pressing the Test switch. This is equivalent to pressing the Test button on the Alarm. For further information see “ACCESSORIES” section.

**5.2.4.** If the Alarm gives a short beep and the amber fault light flashes every 40 seconds it means the self-checking circuit has detected a fault. Press and hold the Test/Hush button. If the amber light flashes without the horn sounding, the sensor is faulty.

**5.2.5.** If the Alarm fails to operate when the Test/Hush button is pressed, switch off the mains supply at the distribution fuse board and remove unit from mounting plate for 3 minutes. Put unit back on mounting plate. Reconnect the mains and test again. (This procedure resets the microprocessor in the unit).

**5.2.6.** If the unit beeps every 40 seconds (without a light flash) it means the battery is depleted. Connect mains power (ensure green light is on) to allow cells to charge.

**5.2.7.** Once a year check the **rechargeable battery** by switching off the mains supply and pressing the Test /Hush button for 10 seconds. The horn should sound loudly. Reconnect the mains supply.

If the Alarm fails any of the above tests it must be replaced immediately (see section 10 “GETTING YOUR CO ALARM SERVICED”).

#### **5.2.8. TESTING WITH CARBON MONOXIDE**

The Test/Hush button on the Alarm is the normal way of testing the Alarm. However, the Alarm can be tested with CO by using one of the kits that comes with CO either in a glass phial or aerosol can. Follow the instructions on the kit. It is best if possible to inject the CO gas into the gas entry holes (see *Figure 4*).

The alarm checks for CO every 4 seconds and as soon as it detects CO, it flashes the red light (as per Table B on page 7) to confirm that is detecting CO gas.

**Testing with CO** does not activate the memory function unless a high level of CO remains in the sensor for a few minutes. (This can be checked by pressing the Test/Hush button. If the red light flashes continuously the memory has been activated - therefore, hold the Test/Hush button for 20 seconds until the red light stops flashing as the memory resets).

## **6. HOW TO DISTINGUISH BETWEEN CO ALARM & SMOKE ALARM WARNINGS**

The CO Alarm has a distinctive on-off sound of 3 pulses followed by a pause, as compared with a typical Smoke/Heat Alarm which has a rapid pulsing sound.

In addition, when your CO Alarm is sounding due to sensing CO, the red alarm light on the cover will be flashing.

Testing both your CO Alarms and Smoke/Heat Alarms weekly will help you and your family to clearly

distinguish between them in an emergency. Note: When the Test Button is pressed on the CO Alarm the red alarm light does not flash unless the CO memory was activated.

If CO Alarms and Smoke/Heat Alarms are interconnected (and are all sounding), press the LOCATE switch on the Ei411H Remote Control Switch to leave just the alarm that has triggered the system sounding.

## 7. MAINTENANCE

Clean the outside case by occasionally wiping with a clean damp cloth (disconnect the mains supply at the distribution/fuse board first). Do not use any cleaning agents, bleaches, detergents or polishes, including those in aerosol cans. Avoid spraying air fresheners, hair spray, paint or other aerosols near the CO Alarm. Do not place air fresheners near the unit.

Use the narrow nozzle of a vacuum cleaner to remove dust and other contamination from the gas entry holes in the cover of the Alarm to ensure CO gas can reach the sensor.

### ! Do not paint the Alarm.

! Remove the Alarm when decorating. Do not allow water or dust to contaminate the Alarm.

! Do not open or tamper with the Alarm. This can damage the unit and may expose the user to shock or fire hazards. There are no user serviceable parts inside apart from the sensor module - see below.

### HOW TO DISCONNECT AND REMOVE THE ALARM:

- (1) Disconnect the mains supply to the Alarm circuit at the distribution/fuse board.
- (2) Remove tamperproofing screw if fitted (see *Figure 4*).
- (3) Release catch (as shown in *Figure 4*) and slide the Alarm off the mounting plate.

### SENSOR MODULE REPLACEMENT

**Replace the sensor module (by the date on the 'REPLACE SENSOR BY' label on the side of the Alarm).** The amber light will flash once every 40 seconds (without a beep) to indicate the sensor should be replaced.

It must also be replaced if the amber light flashes and the unit beeps every 40 seconds as this indicates the sensor is faulty.

- (1) Remove the alarm from the mounting plate as described previously.
- (2) Pull out the sensor module from the rear.
- (3) Replace with a new sensor module (Model No. Ei261MEN - Contact Aico or Ei Electronics, for your nearest module supplier).
- (4) Carefully align the module including the connector pins and push firmly home.
- (5) Remove the 'REPLACE SENSOR BY' label on the side of the alarm.
- (6) Slide the alarm back on to the mounting plate.
- (7) Reconnect the mains supply.
- (8) Wait 4 minutes for the new sensor to stabilise and then press the Test/Hush button - the horn should sound.

**Note:** When the second sensor has completed its period of operation the amber light will flash every 40 seconds. The sensor module can only be replaced once. **The entire Alarm must be replaced by the date given on the 'REPLACE UNIT BY' label on the Alarm.**

## 8. LIMITATIONS OF CO ALARMS

### 8.1 CO Alarms

- The Alarm will not work without mains power and if the rechargeable cells are depleted. The green power light indicates that the Alarm is receiving mains power.
- Carbon Monoxide must enter the unit for it to be detected. There may be Carbon Monoxide in other areas of the house (e.g. downstairs, in a closed room etc) but not in the vicinity of the CO Alarm. Doors, air draughts and obstructions can prevent the CO from reaching the Alarm. For these reasons we



recommend CO Alarms are fitted both near and in bedrooms, particularly if bedroom doors are closed at night. Additionally install in rooms where members of the household spend much of their time, and in rooms with potential sources of CO gas.

- The Alarm may not be heard. The sound output is loud but it may not be heard behind a closed door or if it is too far away. Interconnecting CO Alarms greatly improves the probability that they will be heard. The Alarm may not wake up somebody who has taken alcohol or drugs. The alarm sound may be masked by other sounds such as T.V., stereo, traffic noise etc. Fitting CO Alarms on either side of closed doors will improve their chance of being heard. This Alarm is not designed for people with impaired hearing.

(For deaf people or those with impaired hearing use this CO Alarm in conjunction with an Ei170RF **RadioLINK** Alarm for the Hard of Hearing which has a bright strobe & vibration pad).

- CO Alarms don't last indefinitely. CO Alarms are sophisticated electronic devices with many parts. Although the Alarm and its component parts have undergone stringent tests and are designed to be very reliable, it is possible that parts can fail. Therefore, you should test your Alarm weekly. The Alarm sensor must be replaced by the 'REPLACE SENSOR BY' date on the label on the side of the Alarm. The complete Alarm must be replaced by the date given on the 'REPLACE UNIT BY' label.
- CO Alarms are not a substitute for life insurance. House-holders are responsible for their own insurance. The CO Alarm warns of increasing CO levels, but we do not guarantee that this will protect everyone from CO poisoning.
- CO Alarms are not suitable as early warning Smoke Alarms. Some fires produce Carbon Monoxide, but the response characteristics of these CO Alarms are such that they would not give sufficient warning of fire. Smoke Alarms must be fitted to give early warning of fire.
- This CO Alarm does not detect the presence of natural gas (methane), bottled gas (propane, butane) or other combustible gases. Fit combustion gas alarms to detect these.

**WARNING:** THIS CO ALARM IS DESIGNED TO PROTECT INDIVIDUALS FROM THE ACUTE EFFECTS OF CARBON MONOXIDE EXPOSURE. IT WILL NOT FULLY SAFEGUARD INDIVIDUALS WITH SPECIFIC MEDICAL CONDITIONS. IF IN DOUBT CONSULT A MEDICAL PRACTITIONER.

## 8.2 Limitations of Radio Communications

Ei Electronics radio communication systems are very reliable and are tested to high standards. However, due to their low transmitting power and limited range (required by regulatory bodies) there are some limitations to be considered:

(i) Radio equipment, such as the Ei262 CO Alarm, should be tested regularly - at least weekly. This is to determine whether there are sources of interference preventing communication. The radio paths may be disrupted by moving furniture or renovations, and so regular testing will help identify these and other faults, so that they can be rectified.

(ii) Receivers may be blocked by radio signals occurring on or near their operating frequencies, regardless of the House Coding.

The Ei262 CO Alarm has been tested to EN 300 220-1 V1.3.1 (2000-09) in accordance with the requirements of EN 300 220V1.1.1 (2000-09). These tests are designed to provide reasonable protection against harmful interference in residential installations. This equipment generates, uses and can radiate radio frequency energy and, if not installed and used in accordance with the instructions, may cause interference to radio and/or television reception.

However, there is no guarantee that interference will not occur in a particular installation. If this device does cause such interference, which can be verified by turning the Alarm on and off (disconnect the mains and then remove the Alarm from the mounting plate to disconnect the rechargeable battery). The user is encouraged to eliminate the interference by one or more of the following measures:

(i) Re-orientate or re-locate the unit.

(ii) Increase the distance between the Ei262 CO Alarm and the device being affected.

(iii) Connect the device being affected to a mains outlet on a circuit different from the one that supplies the Ei262.

(iv) Consult the supplier or an experienced radio/television technician.

## 9. HOW TO PROTECT YOUR FAMILY

Follow these guidelines to reduce the risk of Carbon Monoxide poisoning.

- Know and look out for tell-tale signs that Carbon Monoxide may be present. These include:-
  - The CO Alarm warning of abnormal levels.
  - Staining, sooting or discolouration on or around appliances.
  - A pilot light frequently going out.
  - A naked gas flame which is yellow or orange, instead of the normal blue.
  - Family members (including pets) exhibiting the “flu-like” symptoms of CO poisoning (described in Table B).

If any of these signs are present get the appliance checked out by an expert before further use. If family members are ill, get medical help.

- Choose all appliances and vehicles which burn fossil fuels such as coal, oil, natural/bottled gas, paraffin, wood, petrol, diesel, charcoal etc. with care and have them professionally installed and regularly maintained.
- These appliances must “breathe in” air to burn the fuel properly. Know where the air comes from and ensure vents/air bricks etc. remain unobstructed (particularly after building work).
- The appliances must also “breathe out” the waste gases (including the CO) – usually through a flue or chimney. Ensure chimneys and flues are not blocked or leaking, and get them checked every year. Check for excessive rust or cracks on appliances and pipe work.
- Never leave your car, motor bike or lawnmower engine running in the garage with the garage door closed. Never leave the door from the house to the garage open if the car is running.
- Never adjust your own gas pilot lights.
- Never use a gas cooker or a barbecue for home heating.
- Children should be warned of the dangers of CO poisoning and instructed never to touch, or interfere with the CO Alarm. Do not allow small children to press the Test/Hush button as they could be subjected to excessive noise when the unit alarms.

- Leaving windows or doors slightly open (even a few inches) will significantly reduce the risk of high levels of CO occurring. The high levels of draught-proofing in modern houses reduces ventilation and can allow dangerous gases to build up.
- Install CO Alarms in all the areas recommended in this leaflet.
- Recognise that CO poisoning may be the cause when family members suffer from “flu-like” symptoms when at home but feel better when they are away for extended periods.

## **10. GETTING YOUR CO ALARM SERVICED**

If your Alarm fails to work after you have carefully read all the instructions, checked the unit has been installed correctly, and is receiving AC power, return it for repair or replacement. (Do not attach to mounting plate as the Alarm can give beeps or alarm if the Test/Hush button is pressed during shipping). It should be returned in a padded box to “Customer Assistance and Information” at the nearest address given on the back page. State the nature of the fault, where the Alarm was purchased, and the date of purchase.

## **11. FIVE YEAR GUARANTEE**

Ei Electronics guarantees this Carbon Monoxide Alarm for five years from the date of purchase against any defects that are due to faulty materials or workmanship. This guarantee only applies to normal conditions of use and service, and does not include damage resulting from accident, neglect, misuse, unauthorised dismantling, or contamination howsoever caused. This guarantee excludes incidental and consequential damage. If this Carbon Monoxide Alarm should become defective within the guarantee period, it must be returned to the nearest address given on the back page, carefully packaged, with the problem clearly stated (see 10 “GETTING YOUR CO ALARM SERVICED”) along with proof of the date of purchase. We shall at our discretion repair or replace the faulty unit.

## 12. TECHNICAL SPECIFICATIONS

Operating Voltage	: 230±10% VAC, 50Hz
Power	: 1 Watt (90 mA)
Power on Indicator	: Green Light
Sensor	: Electrochemical Sensor
CO Sensitivity	: Meets BS EN 50291: 2001. Unit operates as per Table B.
Apparatus Type	: Apparatus Type A
Conformance to Standards	: 3rd Party tested & Kitemarked to BS EN 50291:2001 by BSI <i>Electrical Safety</i> : Complies with relevant sections of EN 60335-1: 1994 <i>Electromagnetic</i> : Complies with BS EN 50270 including requirements of the R&TTE Directive <i>Compatibility</i> : Compatibility 1999/5/EC (RF Performance to EN300220-3, EMC to EN50270) - independently tested
Test/Hush Button	: Checks electronics and horn. When the Alarm is sounding, after sensing CO, pressing the Test/Hush button will immediately stop the horn (the red alarm light will continue to flash). If CO is still present the red alarm light and the horn will turn on again after about 4 minutes. The Alarm can only be silenced once during a CO incident. At 300 ppm CO the Alarm cannot be silenced. (With interconnected units, the Hush only works on the alarm sensing CO).

- Testing with CO : The red alarm light flashes as soon as the Alarm detects CO, so there is no need to retain CO in the Alarm for several minutes until it sounds.
- Initialisation Time : 70 seconds. On power up red and amber lights flash momentarily to show they are operational.
- Operating Temperature : -10°C to 40°C
- Humidity Range : 15% to 95% R.H. (non-condensing)
- Radio Frequency : 868 MHz band
- RF Power : +5dBm
- Range : 100 meters (minimum) in free space (without use of the “Repeater” function)

**Entering House Code Mode:** Pressing and holding the House Code switch until the green light turns red, then releasing puts the Alarm into House Code mode.

**House Code Mode:** The Alarm transmits and receives specific codes. The green light will flash red every 5 or 10 seconds (depending on number of units coded - up to 12 units, the flashes are every 5 seconds, above 12 units the flashes are every 10 seconds) to indicate the number of House Coded units in the system.

**Duration of House Code Mode:** Exits mode automatically after 30 minutes (Alternatively manually exit by pressing the House Code button; this sends a **RadioLINK** “exit House Code” signal to all other **RadioLINK** units.

**Clearing House Codes:** The House Codes memorised can be deleted (i.e. the Ei262 can be uncoded) by pressing and holding the House Code switch on for about 6 seconds. The red **RadioLINK** Indicator light comes on solidly, then flashes rapidly (alternating with the green light if on mains power) and stops. Release the House Code switch. The Ei262 has now been returned to the default factory setting.

Audible Alarm : 85dB(A) minimum @ 3m

### **Self Diagnostics**

*Sensor* : Horn beep and amber fault light flashes every 40 seconds if a sensor fault is found.

*Rechargeable Lithium Cells:* : Fully charged cells can power unit in standby for over 2 weeks and without mains power, it can power the unit in alarm for over 2 hours. The unit beeps every 40 seconds if cells are depleted.

Tamperproof : Screwdriver needed to release from mounting plate. Additionally a tamper-proofing screw can be fitted to the mounting plate.

**Wireless** Interconnect : Up to 12 Ei262 CO Alarms can be interconnected, so that when one senses CO, all alarm. Alternatively, up to a combined total of 12 Ei262 CO Alarms and Ei161RC/Ei164RC/Ei166RC/Ei2110 Smoke/Heat/Fire Alarms (on Ei168RC **RadioLINK** Professional bases) can be interconnected provided that an Ei411H Remote Control switch is used.

**Hardwired** Interconnect : Up to 12 Ei262 CO Alarms can be interconnected, so that when one senses CO, all alarm. Alternatively, up to a combined total of 12 Ei262 CO Alarms and Ei161RC/Ei164RC/Ei166RC/Ei2110/Ei261RC Smoke/Heat/Fire Alarms can be interconnected provided that an Ei1529RC Remote Control switch is used.

- CO Alarm Memory: : A unit will indicate if it has been in alarm previously by flashing the red light for 2 seconds every 40 seconds (2 flashes for 50 ppm CO, 4 flashes for 100 ppm CO and 8 flashes, for 300 ppm CO). When the Test/Hush button is pressed, the red light flashes (as per Table B on page 8) to indicate the previous CO alarm level detected. The memory is cleared by holding down the Test/Hush button until the red light stops flashing.
- Repeater Function : To disable the Repeater function press and hold the Test/Hush button until the alarm sounds and the red **RadioLINK** light turns on. Immediately (while the red **RadioLINK** light is still on), press and hold the House Code switch with a small screwdriver, until the red indicator light gives 3 slow flashes. Immediately release the House Code switch and Test/Hush button.
- To re-activate the Repeater function just follow the instructions above for disabling. The **RadioLINK** light will flash 15 or 16 times and stop to show the Repeater function is now activated.
- Dimensions : 126 x 150 x 42 mm.                      Weight: 330g.



## 13. ACCESSORIES

### RadioLINK Professional Remote Control Switch Ei411H

(for use with models Ei161RC/164RC/166RC/Ei2110 Alarm on an Ei168RC Base & Ei262 CO Alarm only)

The **RadioLINK** Remote Control Switch is recommended for systems with at least one Carbon Monoxide Alarm and one or more Smoke / Heat / Fire Alarms. It allows the user to perform the following functions from a remote location:

LOCATE - If alarms sound press *Locate* to identify the source of the alarm (audibly).

HUSH - Press *Hush* to silence nuisance alarms.

TEST - Operate weekly to *Test* the alarms.

### RadioLINK Professional Relay Module Ei428

This module is a device that switches an internal relay upon receipt of an alarm signal from a **RadioLINK** device – useful for turning off gas valves, signalling to panels, turning on strobes etc. It is mains powered with battery back-up.

### RadioLINK Professional Base Ei168RC

The Ei262 CO Alarm can be interconnected to any Ei161RC/Ei164RC/Ei166RC/Ei2110 Smoke/Heat/Fire Alarm on an Ei168RC **RadioLINK** Professional base ( provided an Ei411H Remote Control Switch is also used).

### RadioLINK Professional Alarm for the Deaf & Hearing Ei170RF

For use with **RadioLINK** Professional Smoke/Heat/Fire/CO Alarms. With built-in Strobe and vibration pad.

## 14. TROUBLESHOOTING

### TROUBLESHOOTING THE RF LINK

If when checking the **RadioLINK** interconnection some of the Alarms do not respond to the button test, then:

(i) Ensure you have held the Test/Hush button down for up to 10 seconds and the **RadioLINK** Indicator light has come on continuously for 3.5 seconds.

(ii) Re-locate/rotate the units. There are a number of reasons why the radio signals may not reach all the Carbon Monoxide / Smoke Alarms in your system (see Section 8.2 on “Limitations of Radio Communications”). Try rotating the units or re-locating the units (e.g. move them away from metal surfaces or wiring) as this can significantly improve signal reception.

Rotating and/or relocating the units may move them out of the range of existing units even though they may have already been House Coded correctly in the system. It is important therefore to check that all Alarms are communicating in their final installed positions. If units are rotated and/or resited, we recommend that all units are returned to the factory settings - see section 12 “Technical Specifications” on how to clear House Codes. Then House Code all units again in their final positions as per Section 4 “Installation”. The **RadioLINK** interconnection should then be checked by counting the number of flashes and button testing all units.

(iii) Add another **RadioLINK** unit to act as a Repeater.

**Note:** The Ei262 will only transmit **RadioLINK** alarm signals as long as it is detecting Carbon Monoxide (or for 30 minutes) whichever is the shorter. This is to prolong the battery life in other **RadioLINK** units which may just have primary batteries. The Ei262 will continue to sound as long as the Carbon Monoxide gas is present.

#### 1. ALARM DOES NOT WORK WHEN THE TEST BUTTON IS PRESSED:

- Check that the green mains power light is on. If it is off check the wiring, fuse, circuit breakers etc.
- Hold the Test/Hush button down for at least 5 seconds.

- Turn off mains power, remove from mounting plate (see Figure 4) for 3 minutes and re-install (this resets the Alarm).

## **2. ALARM BEEPS AND AMBER LIGHT FLASHES EVERY 40 SECONDS:**

- If the alarm beeps and the amber fault light flashes every 40 seconds, the CO sensor is probably defective.
- Press the Test/Hush button for approximately 20 seconds to reset the unit. If the beeping and the amber light flashing re-occurs replace the sensor module.

## **3. ALARM BEEPS EVERY 40 SECONDS (without amber light flashing):**

- Rechargeable cells depleted. Reconnect mains power if green light is off.

## **4. ALARM SOUNDS FOR NO APPARENT REASON:**

Follow the detailed instructions in Section 1 on page 4 entitled “WHAT TO DO WHEN THE ALARM SOUNDS”. If there are still problems:

- Ensure there are no fuel-burning appliances in the vicinity which could be leaking CO gas (e.g. even from next door).
- Ensure there are no fumes in the area (e.g. paint, thinners, alcohol, hair spray, chemical cleaners aerosol sprays etc).
- Ensure there is no outdoor source of CO in the vicinity (e.g. a car with engine running, heavy traffic, heavy air pollution, barbecue fumes etc).
- Press the Test/Hush button to silence the alarm.

If the unit continues to sound it is possibly defective and should be replaced. Follow the instructions in “GETTING YOUR CO ALARM SERVICED”.

## **5. Test/Hush BUTTON DOES NOT SILENCE ALARMS:**

If there are a number of alarms interconnected and they are all sounding, pressing the Test/Hush button on the unit sensing CO (i.e. the one with the red light flashing) will silence the system. Pressing any other

Test/Hush button will not silence the Alarms. The Test/Hush button will only silence the unit once at CO levels less than 300 ppm CO during a CO incident.

Alternatively, if an optional Ei411H **RadioLINK** Remote Control Switch is fitted, pressing the LOCATE switch when all the Alarms are sounding will silence all Alarms, apart from the Alarm that is sensing CO or fire.

This area can then be safely investigated and if determined that it is a false alarm, press the HUSH switch to silence the alarm.

The crossed out wheelie bin symbol that is on your product indicates that this product should not be disposed of via the normal household waste stream. Proper disposal will prevent possible harm to the environment or to human health. When disposing of this product please separate it from other waste streams to ensure that it can be recycled in an environmentally sound manner. For more details on collection and proper disposal, please contact your local government office or the retailer where you purchased this product.



**Aico Ltd.** Mile End Business Park, Maesbury Rd, Oswestry, Shropshire SY10 8NN, U.K.

Tel: 0870 758 4000

**[www.aico.co.uk](http://www.aico.co.uk)**

**Ei Electronics.** Shannon, Co Clare, Ireland.

Tel: +353 (0)61 471277

**[www.eielectronics.com](http://www.eielectronics.com)**